

# Flushless Seal for CHOPX Chopper Pumps

- No Dilution to the Process
- Elimination of Flush Piping, Valves, Guages etc.
- Lower Capital and Operating Costs
- Increased Process Efficiencies

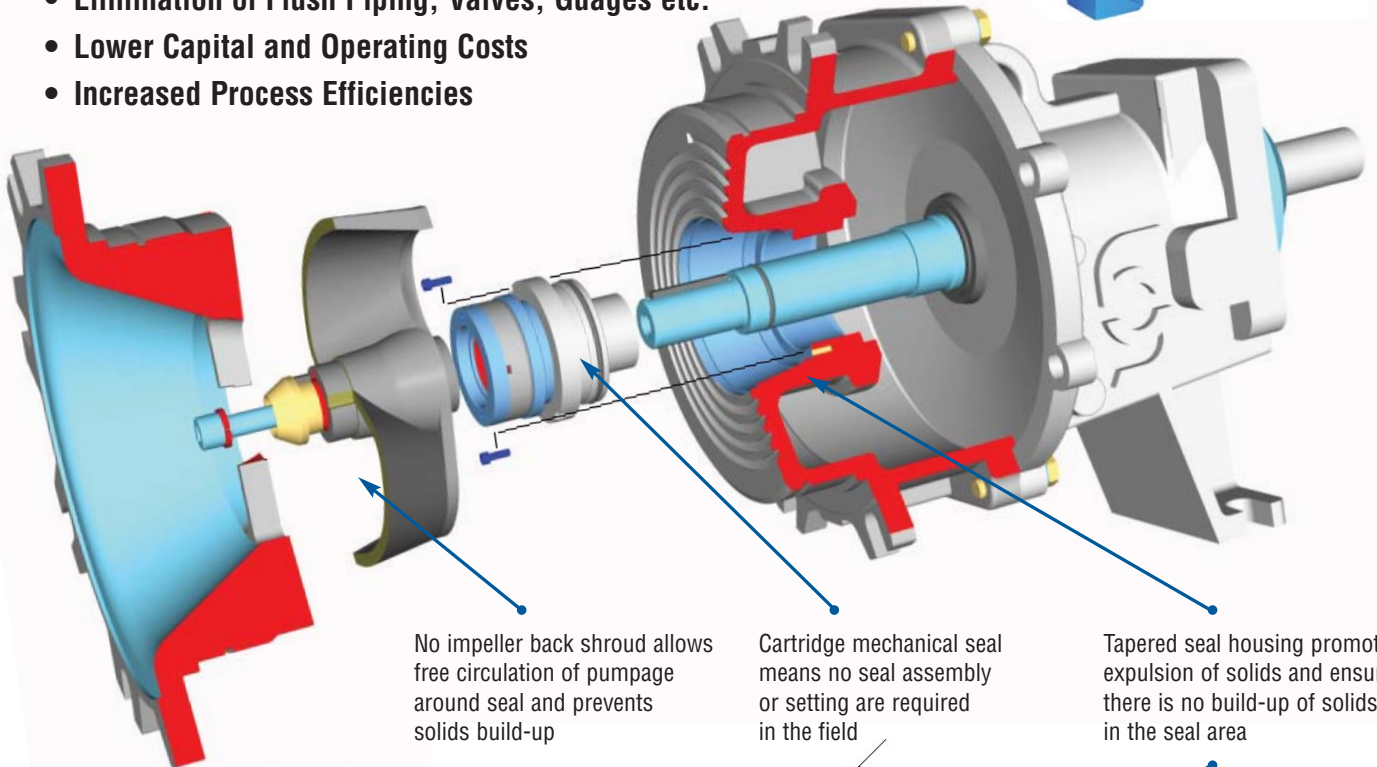

No impeller back shroud allows free circulation of pumpage around seal and prevents solids build-up

Cartridge mechanical seal means no seal assembly or setting are required in the field

Tapered seal housing promotes expulsion of solids and ensures there is no build-up of solids in the seal area

## Applications Include

- Digester Recirculation
- Sludge Transfer
- Scum Pits
- Lift Stations
- Food Processing

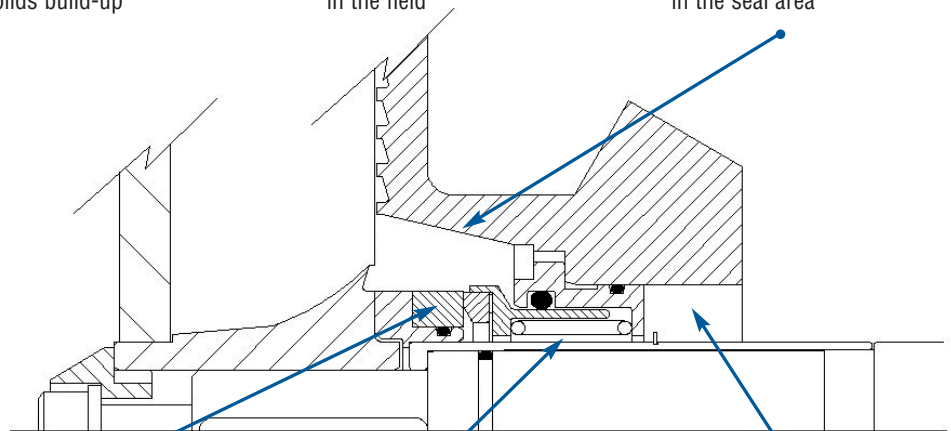

Hard seal faces (silicon carbide) ensures maximum seal life in the most severe applications

Seal spring is shielded from pumpage to ensure unimpeded function

No oil quench required. Monitoring oil level and nuisance oil leakage is eliminated

**Toronto (Head Office)**  
Tel: (905) 693-8595  
Fax: (905) 693-1452

**Montreal**  
Tel: (514) 697-6445  
Fax: (514) 697-1164

**Calgary**  
Tel: (403) 253-2737  
Fax: (403) 253-1353

**Vancouver**  
Tel: (604) 986-8764  
Fax: (604) 986-8794