

Diverter Valve and Recirculation Nozzle Assembly

- Chop, re-circulate, mix and pump out tanks & basins with one system
- Available with submersible or vertical CHOPX pumps
- Suspend and incorporate solids prior to pump out
- Break-up and incorporate scum blankets

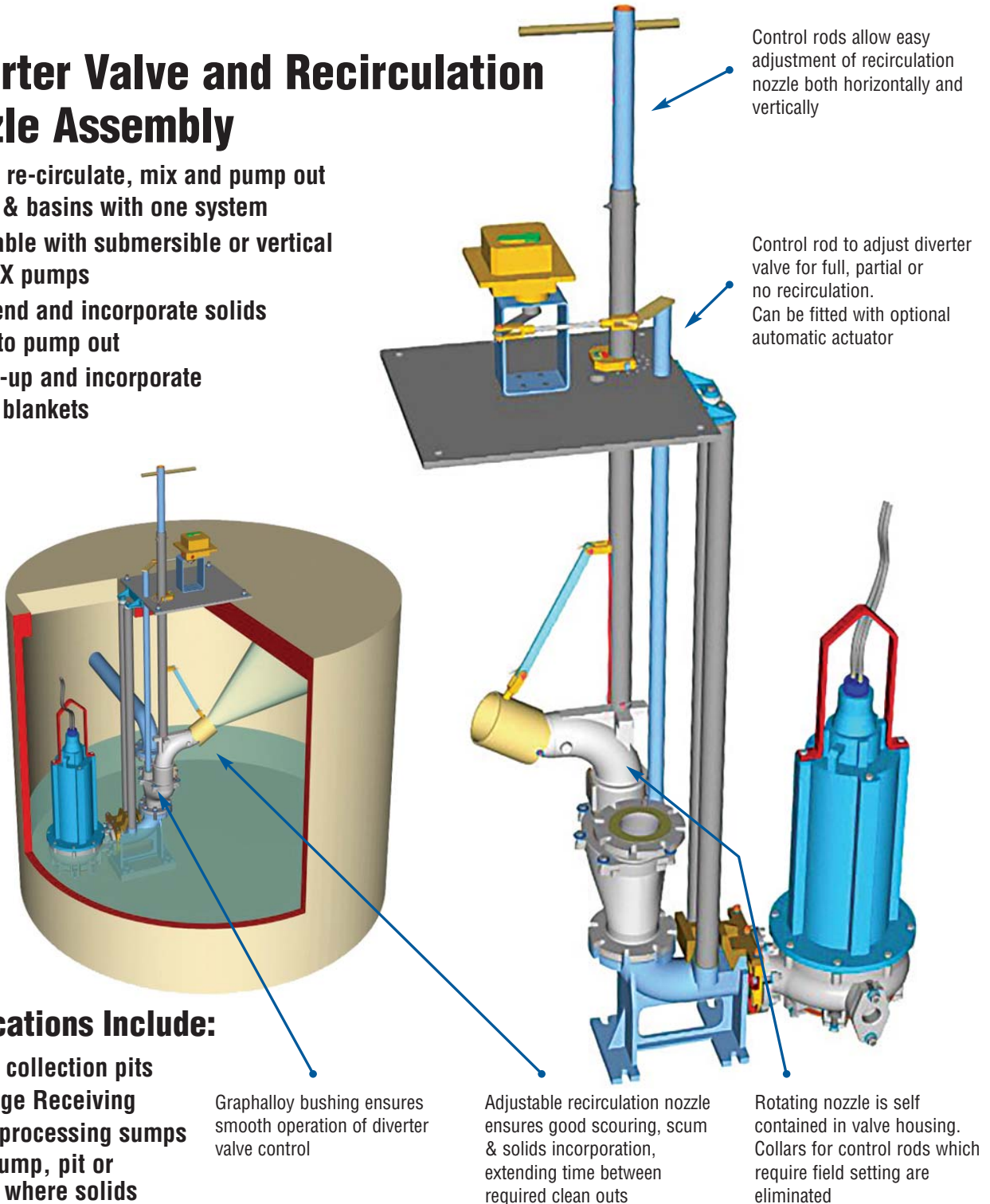

Applications Include:

- Scum collection pits
- Septage Receiving
- Food processing sumps
- Any sump, pit or basin where solids build-up is a problem

Features and Benefits

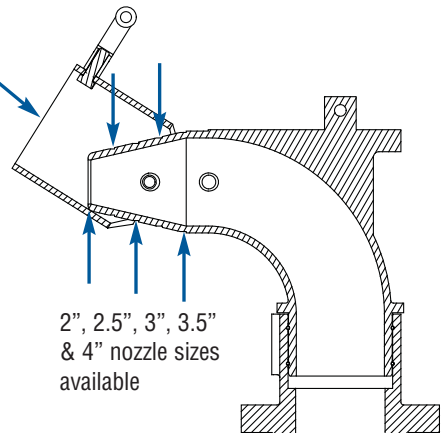
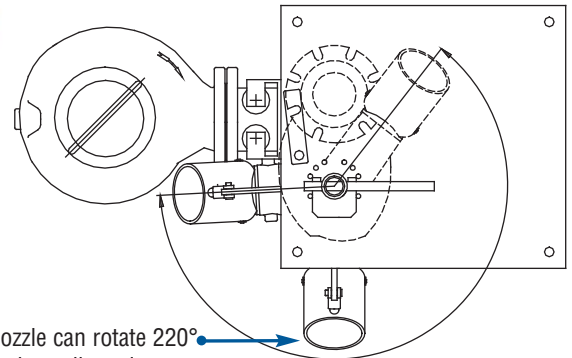
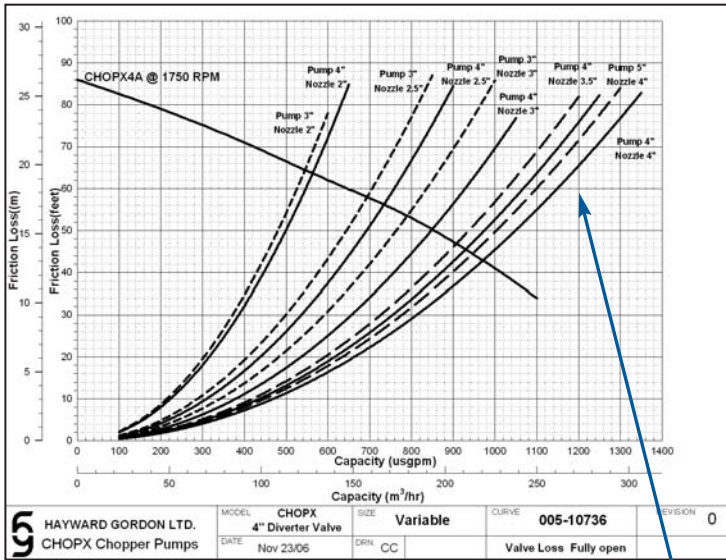
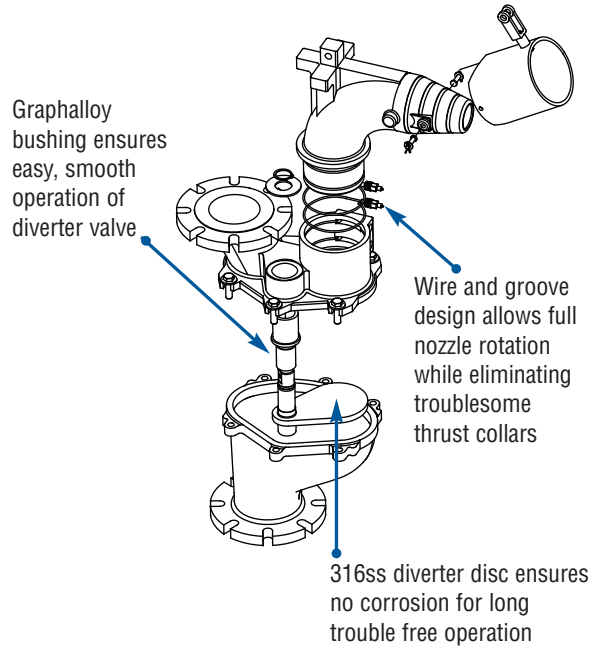
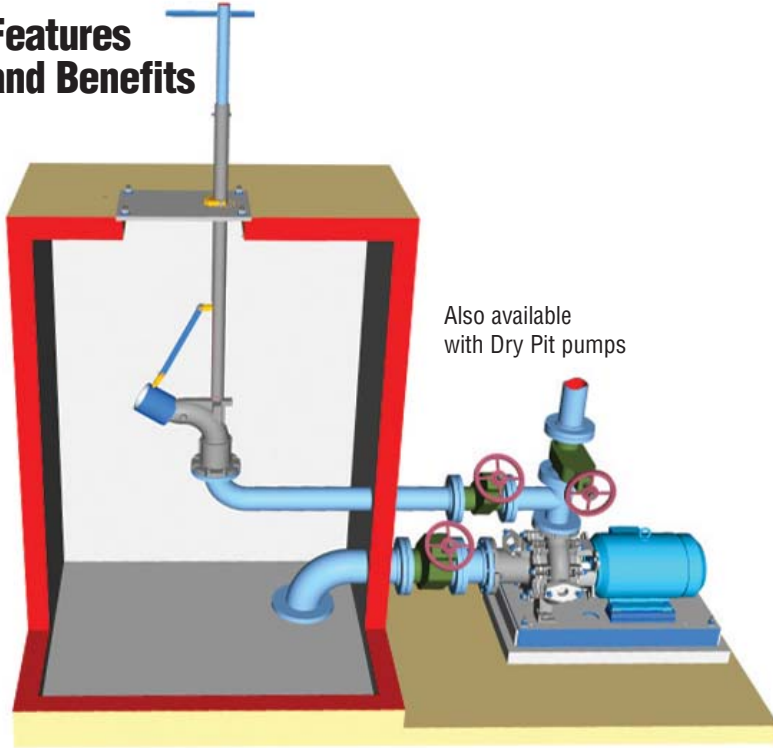

Trimmable nozzle allows optimum flow selection for each application, i.e. mixing different basin sizes & geometries



U.S.A.
1051 Clinton Street
Buffalo, New York 14206
(716) 856-4636

CANADA
5 Brigden Gate
Halton Hills, ON L7G 0A3
(905) 693-8595 Fax (905) 693-1452

**Western U.S.A./
Western Canada**
(604) 986-8764
Fax (604) 986-8794

haywardgordon.com
info@haywardgordon.com

HGDIVERT04/09-2M

Printed in Canada